



LIMITED ONE-YEAR WARRANTY (INSULATED COVERS)

THE SELLER NAMED BELOW MAKES THE FOLLOWING WARRANTY WITH RESPECT TO THE DOMETIC PRODUCT:

1. This Warranty is made only to the first purchaser (hereinafter referred to as the "Original Purchaser"), who acquires the Dometic Product for his or her own use and when the Dometic Product is installed and operated within the continental United States and Canada.
2. **WARRANTY PERIOD:** This Warranty will be in effect for one (1) year from the date of purchase by the Original Purchaser. The Original Purchaser should retain a copy of the dated bill of sale as evidence of the date of purchase.
3. **WARRANTY:** This Warranty covers labor, specified parts, and freight. The Dometic Product shall be free from defects in material and workmanship at the time of sale and under normal use. All Dometic Products (except those specifically built for commercial use) are warranted only when installed per the Seller's installation instructions on vehicles built to R.V.I.A. A119-2 and C.R.V.A. Z-240 Standards. This Warranty does NOT cover conditions unrelated to the material and workmanship of the Dometic Product. Such unrelated conditions include, but are not limited to: (a) damage not reported within 10 days of ownership; (b) failure or damage caused by storms, rain, lightning, or any acts of God; (c) faulty installation or installation that does not comply with the Seller's instructions or R.V.I.A. and C.R.V.A. standards, and any damage resulting from such; (d) damage or failure caused by installation of accessories not manufactured and marketed by the Seller or any non-Dometic parts that are installed as replacement parts; (e) the need for normal maintenance and any damage resulting from the failure to provide such maintenance; (f) failure to follow Seller's instructions for use of this Dometic Product; (g) any accident to, or misuse of, any part of the Dometic Product and any alteration by anyone other than the Seller or its authorized representative; (h) cosmetic issues caused during installation; (i) normal wear, including scratches or dents; and (j) Dometic Product abuse.
4. **WARRANTY COVERS DOMETIC COMPONENT PARTS:** All Dometic component parts are covered under this Limited Warranty.
5. **WARRANTY REMEDY:** In order to obtain the benefits of this Warranty, the Original Purchaser has the following two options during the WARRANTY PERIOD:
 - a. Preferred option: Deliver the Dometic Product for inspection to the nearest Authorized Dometic Service Center during the Warranty Period. To obtain the location of the nearest Authorized Dometic Service Center, refer to <https://www.dometic.com/en-us/us/find-a-dealer>. The Authorized Dometic Service Center will work with the Seller to obtain Warranty coverage if a Seller defect is identified. **CONFIRM THE SERVICE CENTER IS AN AUTHORIZED DOMETIC SERVICE CENTER. DO NOT PAY THE SERVICE CENTER FOR WARRANTY REPAIRS.**
 - b. Second option: If it is not feasible under the circumstances to deliver the Dometic Product to an Authorized Dometic Service Center, please call 1-800-544-4881 for additional Warranty assistance. Seller prefers option a. first and only option b. if option a. is determined not to be feasible under the circumstances.
6. Any item returned in the manner described in paragraph 5 will be examined by the Authorized Dometic Service Center. If it is found that the returned item was defective in material and workmanship at the time of sale, the Authorized Dometic Service Center will contact the Seller for Warranty coverage. The Seller shall, at Dometic's sole option, repair or replace the Dometic Product, or refund Original Purchaser's purchase price. If the Seller determines that repairs to the Dometic Product are to be made, then only authorized Dometic parts will be used.
7. The Seller does not authorize any person or company to create any Warranty obligations or liability on its behalf. This Warranty is not extended by the length of time which you are deprived of the use of the Dometic Product.
8. **IN NO EVENT SHALL SELLER BE LIABLE FOR EITHER INCIDENTAL OR CONSEQUENTIAL DAMAGES. THIS INCLUDES ANY DAMAGE TO ANOTHER PRODUCT OR PRODUCTS RESULTING FROM SUCH A DEFECT. SOME STATES DO NOT ALLOW THE EXCLUSION OR LIMITATION OF INCIDENTAL OR CONSEQUENTIAL DAMAGES, SO THE ABOVE LIMITATIONS MAY NOT APPLY TO YOU.**
9. **ANY IMPLIED WARRANTY, INCLUDING THE IMPLIED WARRANTY OF MERCHANTABILITY AND FITNESS FOR ANY PURPOSE, IS LIMITED TO THE DURATION OF THIS LIMITED WARRANTY. SOME STATES DO NOT ALLOW LIMITATIONS ON HOW LONG AN IMPLIED WARRANTY LASTS, SO THE ABOVE LIMITATION MAY NOT APPLY TO YOU.**
10. **THIS WARRANTY GIVES SPECIFIC LEGAL RIGHTS, YOU MAY ALSO HAVE OTHER RIGHTS WHICH VARY FROM STATE TO STATE.** No action to enforce this Warranty shall be commenced later than ninety (90) days after the expiration of the Warranty Period. Claims must be submitted in writing to the Dometic Warranty Department.
11. The Seller reserves the right to change the design of any Dometic product without notice and with no obligation to make corresponding changes in Dometic products previously manufactured.

PROTECTION FOR YOUR NEW INVESTMENT

We appreciate that you have chosen to purchase a Dometic product for your recreational vehicle and we want to help you protect this wise investment. We at Dometic, back our products with one of the most comprehensive warranties in the industry. **Register your product online at: www.eDometic.com.**

Dometic Corporation

Warranty Department
1120 North Main Street
Elkhart, Indiana 46514
1-574-294-2511
Register Your Product @
www.eDometic.com

REVISION

Form No. 3316993.000 (10/17)
(French 3316994.000)
©2017 Dometic Corporation
LaGrange, IN 46761

Customer Service Group
1120 N. Main Street
Elkhart, IN 46516
800.544.4881
www.eDometic.com

Form No. 3316989.000 12/17 | ©2017 Dometic Corporation



REFRIGERATION INSULATED COVERS

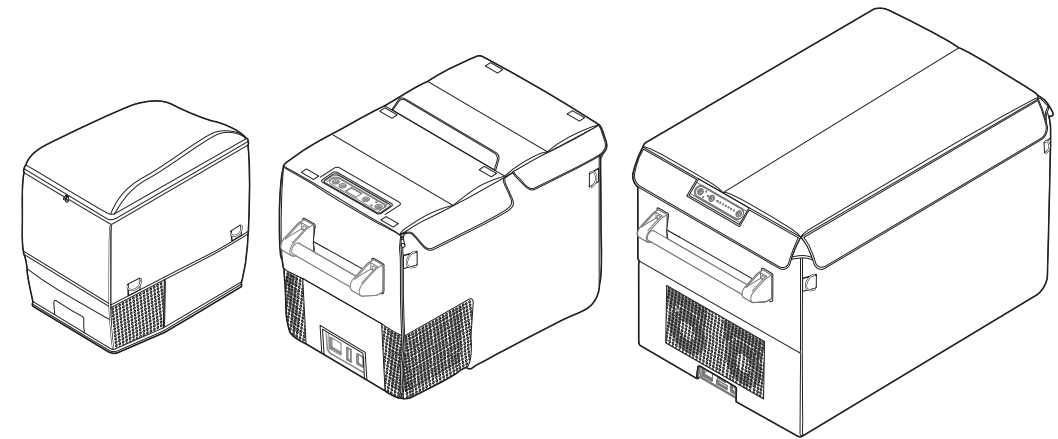

CF18, CF25, CF35, CF40, CF50, CF80, CF110

EN

CF Insulated Covers
Installation Manual

DIMENSIONS

Model	Dimensions (W x H x D)
CF18	19.13" x 12.0" x 16.6"
CF25	24.1" x 9.9" x 15.4"
CF35	23.7" x 13.8" x 13.8"
CF40	22.1" x 13.8" x 17.0"
CF50	24.5" x 14.2" x 18.5"
CF80	30.8" x 19.7" x 16.6"
CF110	30.8" x 19.7" x 16.6"

CARE AND CLEANING

- Clean the cover regularly using a sponge or clean towel with clean water. Do **not** use chemical solvents or abrasive cleaners.

INSTALLATION

CF18:

- Place the cooler on top of the cover bottom panel.
- Slide the cover sides onto the cooler and zip them to the cover bottom panel. Be sure to line up the mesh on the cover with the vents on the cooler.

CF25, CF35, CF40, CF50, CF80, CF110:

- Place the cooler in the cover through the open top and side panels. Be sure to line up the mesh on the cover with the vents on the cooler.

CF18

- Place the cover top panel over the cooler.
- Zip around the sides of the cover to secure it in place.

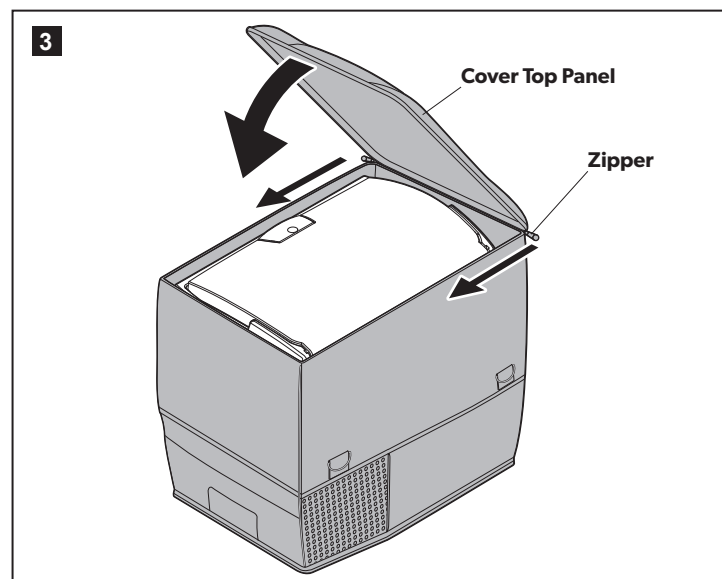
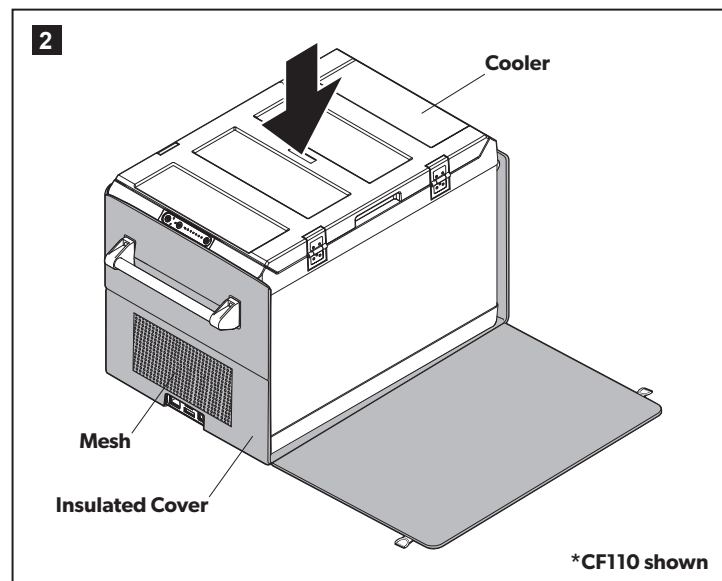
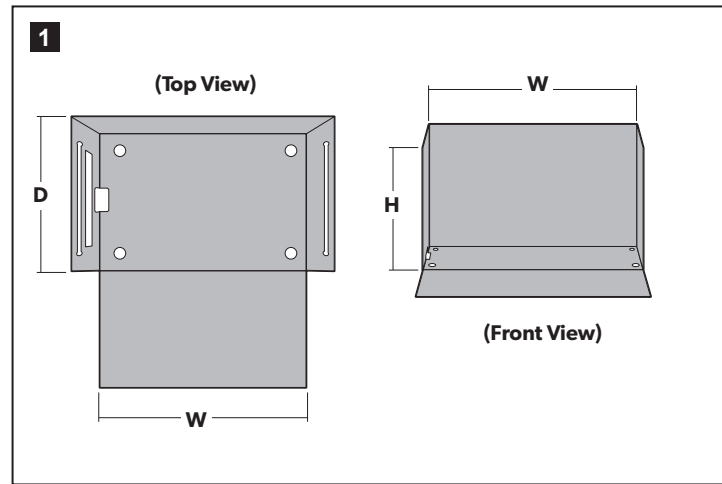

CF25, CF35, CF40

- Zip up the side of the cover, around the top, and down the opposite side.

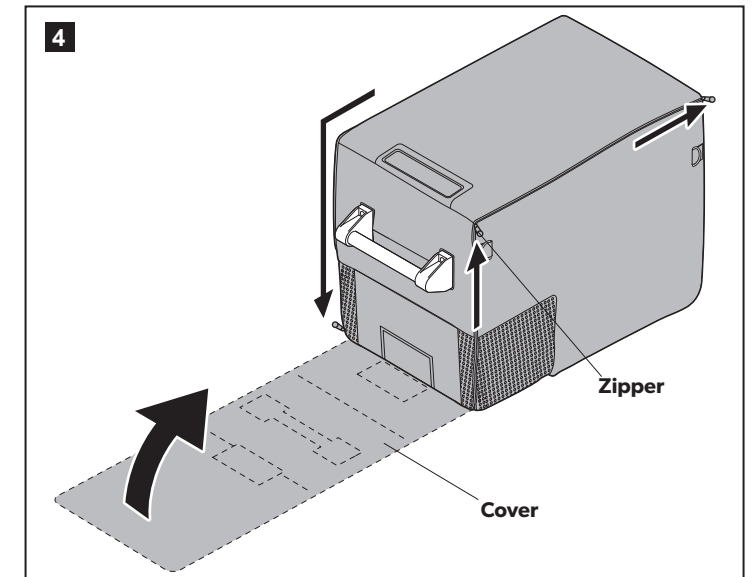

CF50

- Zip up the cover side panel.
- Place the cover top panels over the cooler and flip the top cover flaps over the cover side panels.

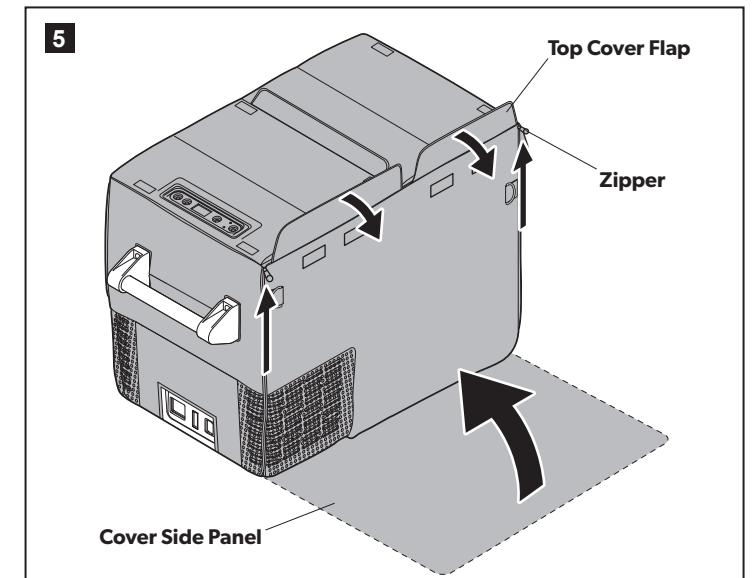

CF80, CF110

- Zip up the cover side panel.
- Place the top cover over the cooler.

