

OPTIMA

TENSION RAFTER SYSTEM

- **Optima Tension Rafter/Cradle Support;**
- **Optima Center Support;**
- **Optima Tension Rafter/Cradle Support with Center Support Combo**

USA

SERVICE OFFICE
Dometic Corporation
1120 North Main Street
Elkhart, IN 46514

CANADA

Dometic Corporation
46 Zatonski, Unit 3
Brantford, ON N3T 5L8
CANADA

SERVICE CENTER & DEALER LOCATIONS

Please Visit:
www.eDometic.com

WARNING

This manual must be read and understood before installation, adjustment, service, or maintenance is performed. This unit must be installed by a qualified service technician. Modification of this product can be extremely hazardous and could result in personal injury or property damage.

AVERTISSEMENT

Lire et comprendre ce manuel avant de procéder à l'installation, à des réglages, de l'entretien ou des réparations. L'installation de cet appareil doit être effectuée par un réparateur qualifié. Toute modification de cet appareil peut être extrêmement dangereuse et entraîner des blessures ou dommages matériels.

INSTALLATION & OPERATING INSTRUCTIONS

OPTIMA
TENSION
RAFTER

REVISION A

Form No. 3103784.033 10/16
(French 3108200.027_A)
©2016 Dometic Corporation
LaGrange, IN 46761

SAFETY INSTRUCTIONS

This manual has safety information and instructions to help users eliminate or reduce the risk of accidents and injuries.

RECOGNIZE SAFETY INFORMATION



This is the safety-alert symbol. When you see this symbol in this manual, be alert to the potential for personal injury.

Follow recommended precautions and safe operating instructions.

UNDERSTAND SIGNAL WORDS

A signal word, **WARNING OR CAUTION** is used with the safety-alert symbol. They give the level of risk for potential injury.

WARNING indicates a potentially hazardous situation which, if not avoided, could result in death or serious injury.

CAUTION indicates a potentially hazardous situation which, if not avoided, may result in minor or moderate injury.

CAUTION used without the safety alert symbol indicates, a potentially hazardous situation which, if not avoided, may result in property damage.

Read and follow all safety information and instructions.

OPTIMA TENSION RAFTER SYSTEM INSTALLATION/OPERATION

For Installation of: Optima Tension Rafter/Cradle Support; Optima Center Support and Optima Tension Rafter/Cradle Support with Center Support Combo

APPLICATION:

The Optima Tension Rafter System works on any automatic roll-up type awning that uses a roller tube. It is available as a complete system including self-adjusting Tension Rafter, Center Support and Storage Cradle in one attractive package; or separately as a Center Support or Tension Rafter/Cradle Support.

IMPORTANT: Read and understand the entire installation procedure before starting installation.

NOTE: Dometic Corporation assumes no liability for damages or injuries resulting from installation or operation of this product.

Dometic Corporation reserves the right to modify appearances and specifications without notice.

INSTALLATION OF TENSION RAFTER

Tools required:

- Measuring Tape
- Electric Drill
- Drill Bits: #7 or 3/16"; 5/16"
- Center Punch
- Phillips Screwdriver
- Silicone Sealant
- Ladder
- Pencil
- Wrench or Socket: 7/16"
- Pop Rivet Gun (Necessary only if Backing Plate is needed)

1. Install Black Adjustment Knob on left side of tension rafter. (See FIG. 1).

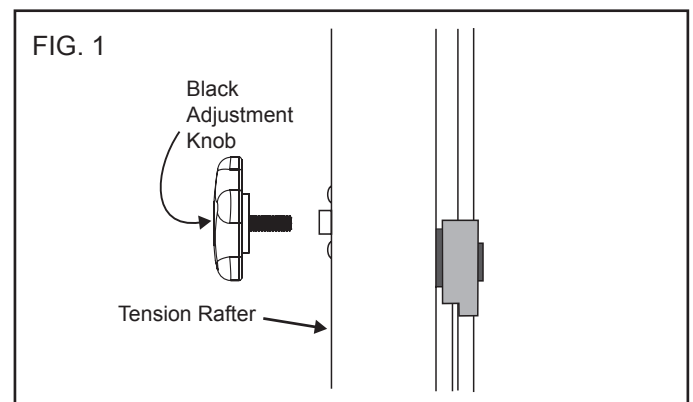

2. A. Attach the tension rafter to the top bracket/pad assembly with the 1/4-20 x 2-1/2" hex head bolt and 1/4-20 lock nut with nylon insert provided. (See FIG. 2A)

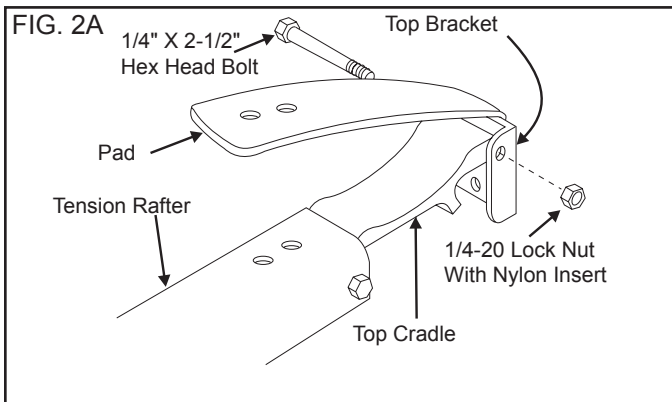

- B. With awning closed, position the tension rafter at the center of the awning so that it has a minimum of 69" of unobstructed clearance below the awning rail. If windows and/or service accesses interfere, relocate tension rafter as close to center of awning as the situation will allow. (See FIG. 2B).

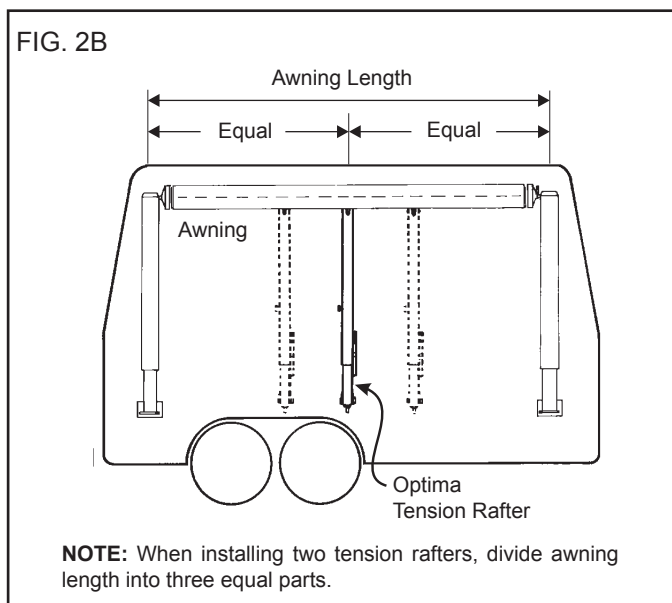

NOTE: When installing two tension rafters, divide awning length into three equal parts.

- C. While holding tension rafter vertically at mounting location, carefully set roller bracket end of tension rafter on ground and loosen black adjustment knob on side of tension rafter.
- D. With tension rafter still resting on ground, extend the tension rafter up so that the top of the tension rafter almost touches the bottom of the closed awning.
- E. Lock black adjustment knob on side of awning.
- F. Carefully climb ladder. With tension rafter still resting on the ground, position the top bracket/pad assembly against the vehicle so that the top cradle of the tension rafter touches the bottom of the closed awning as shown in FIG. 3.

NOTE: It may be necessary to slightly extend the tension rafter further to obtain the right angle shown in FIG. 3.

IMPORTANT: Tension rafter, top cradle, top bracket, and vehicle **MUST** form right angles as shown in FIG. 3 for tension rafter to operate correctly.

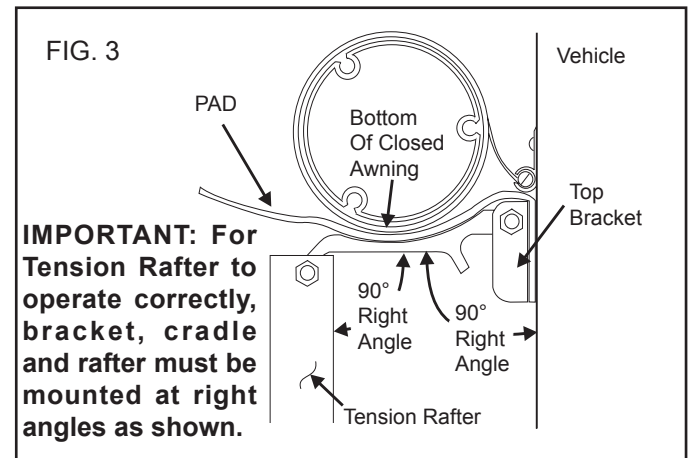

- G. Once right angles are established, mark location of mounting holes in top bracket on vehicle.
 - H. Detach top bracket/pad assembly from tension rafter by removing the 1/4-20 x 2-1/2" hex head bolt and 1/4-20 lock nut.
3. A. Position top bracket/pad assembly against vehicle and predrill with #7 or 3/16" drill bit.
 - B. Secure using three (3) #14 x 1-1/2" pan head screws provided with a small dab of silicone sealant on each screw. (See FIG. 4)

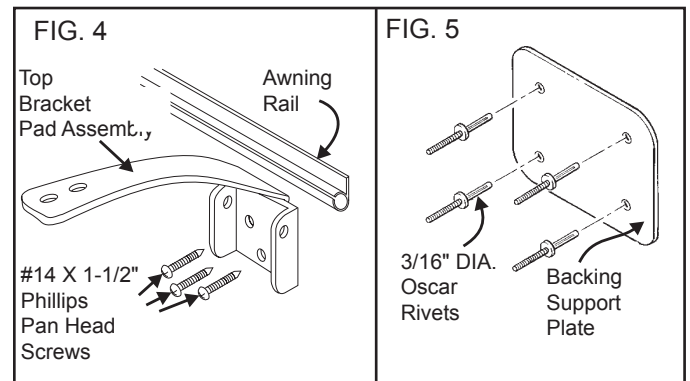

NOTE: Be sure to use a dab of silicone sealant on every screw or rivet where a hole has been drilled in the side of the vehicle. This will prevent possible water leakage.

4. **USE OF BACKING SUPPORT PLATE (FIG. 5)**
For installations where there is not sufficient support for mounting the top bracket, install the supplied backing support plate as follows:
 - A. Using the support plate as a template, mark and drill four (4) 3/16" dia. holes through the vehicle side.

- B. Secure the plate using the 3/16" dia. oscar rivets provided. Plate should be pushed up and touch rail. (See FIG. 5)
- C. Proceed with installation by installing the top bracket of the tension rafter directly onto the backing support plate.
- 5. Reattach the tension rafter to the top bracket with the 1/4-20 x 2-1/2" hex head bolt and 1/4-20 lock nut with nylon insert provided. (See FIG. 2A)
- 6. A. Attach the bottom bracket to the roller bracket using the ball lock pin. (See FIG. 6A)
- B. Position the bottom bracket over the floor line, or solid structural member, 69" or more below the awning rail.

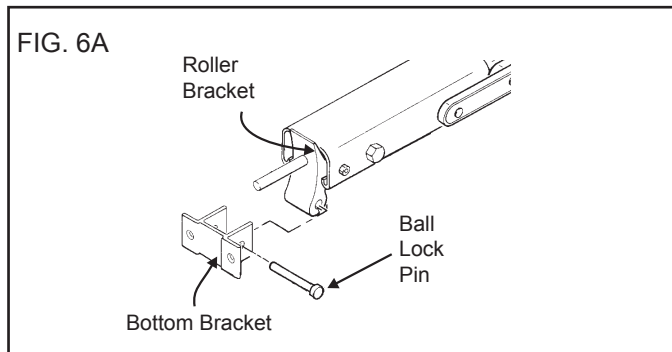

IMPORTANT: The bottom bracket MUST be mounted to the floorline or solid structural member. If these are not available, the vehicle shell must be adequately reinforced.

- C. With the tension rafter hanging straight down from the top bracket, mark the bottom bracket screw placements.
- D. Detach bottom bracket and predrill two (2) #7 or 3/16" dia. holes.
- E. Secure bottom bracket with two (2) #14 or 1-1/2" pan head screws with a small dab of silicone sealant on each screw. (See FIG. 6B)
- F. Attach tension rafter to bottom bracket using ball lock pin. (See FIG. 6C).
- G. Attach pad to tension rafter with the supplied push-in panel fasteners. (See FIG. 6D)

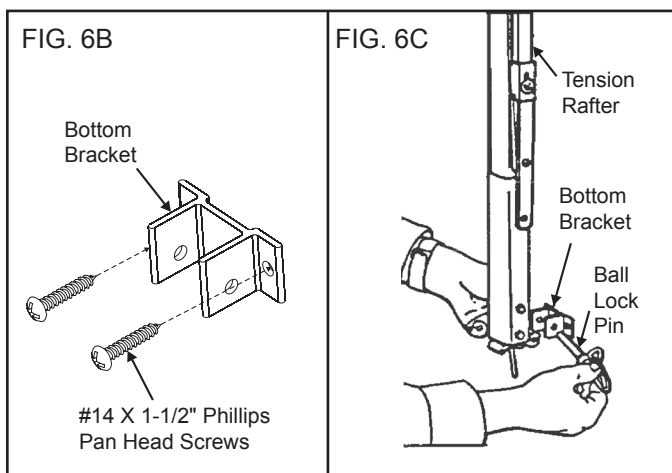

NOTE: When installing the tension rafter on a curved vehicle which does not allow for rafter storage, bottom bracket installation is not required.

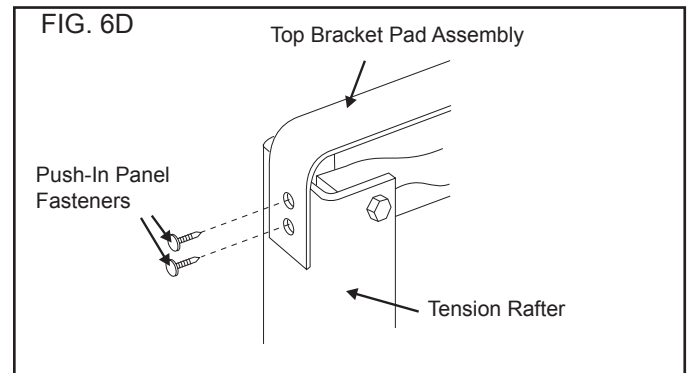

7. FOR USE ON AWNINGS WITH VALANCE THAT HANGS FROM FRONT OR BOTTOM OF ROLLER TUBE. (SEE FIG. 7)

Note: If valance hangs behind roller tube, opposite of that shown in figure 7 then awning is over or under extended. Adjust valance position to front or bottom of roller tube so that the fabric is taut.

- A. Extend the awning to the fully open position, disconnect tension rafter from bottom bracket and swing it up into position making sure the rafter is perpendicular to the roller tube.
- B. Mark the spot on the roller tube where the dowel of the roller bracket is to be inserted 1-1/4" below the fabric. (See FIG. 7)

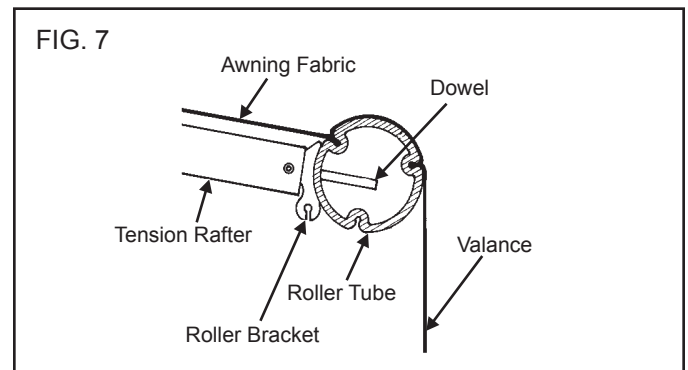

- C. To prevent damaging the fabric, first center-punch the dowel hole or pilot drill, using a small drill bit.
- D. Use a 5/16" dia. bit to drill dowel hole into roller tube.
- 8. TO TENSION FABRIC: See Operating Instruction Section TO TENSION FABRIC beginning with Step 4.
- 9. TO STORE AWNING: See Operating Instruction Section TO CLOSE beginning with Step 17.

⚠ CAUTION

DO NOT attempt to close awning until tension rafter is in the correct storage position described in Operating Instructions TO CLOSE Step 17, or damage to the awning may occur.

OPERATING OF TENSION RAFTER

TO TENSION FABRIC

1. A. From awning travel position, release pressure on Optima Tension Rafter by sliding lock on lift/tension mechanism lever up and pulling lever forward. Roller should be as high up as you can reach as the roller and rafter pivot at different locations. (FIGS. 1A & 1B)
- B. Roll out awning per awning Operating Instructions.
- C. Raise awning roller tube to eye level or a position that is comfortable to reach.

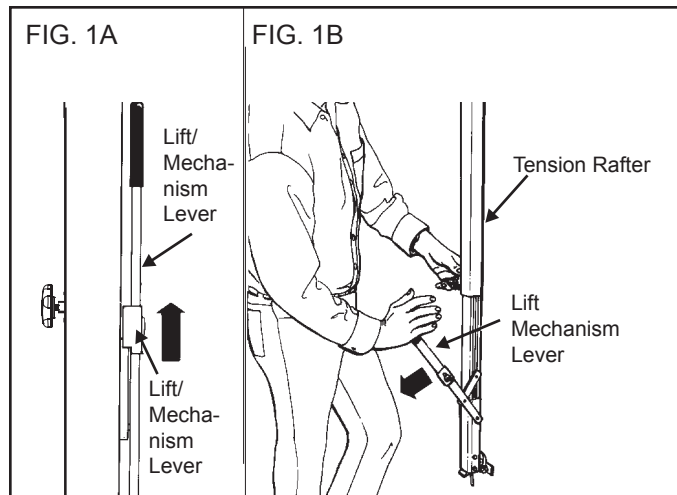

2. Remove the ball lock pin while grasping the bottom section of the tension rafter. Detach the tension rafter and replace pin in bottom bracket. (FIG. 2)

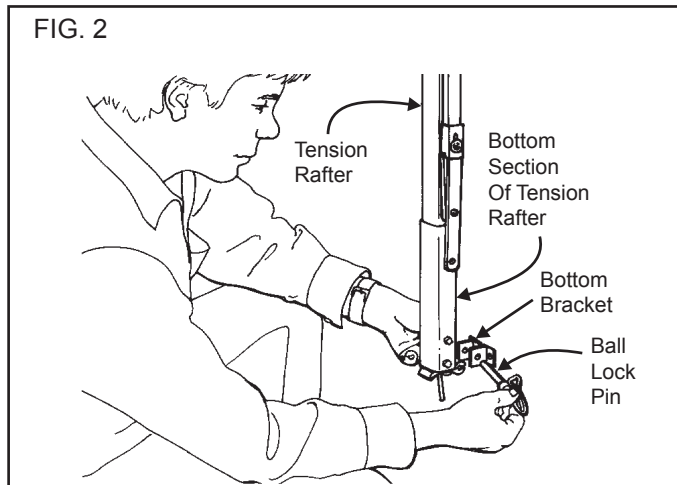

3. While raising the tension rafter toward the awning roller tube, loosen the adjusting knob on the left side of the tension rafter. (FIG. 3)

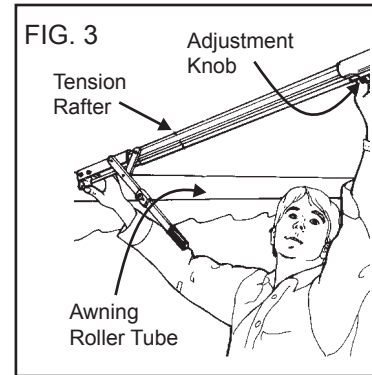

4. Extend tension rafter and attach it to awning roller tube by inserting dowel at end of rafter into drilled hole in roller tube. (FIG. 4)

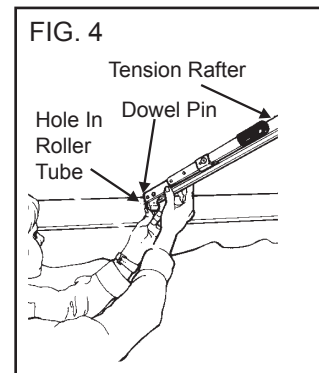

5. Slide lock tension mechanism up and pull lever down while holding dowel pin at end of rafter in roller tube. (FIGS. 5A & 5B)

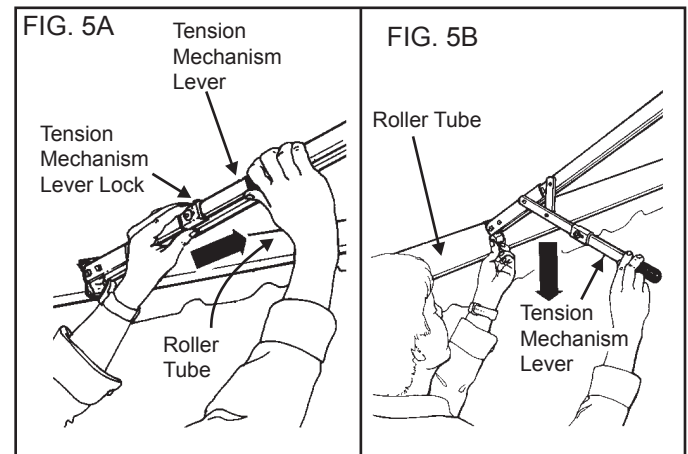

6. A. Firmly tighten adjustment knob on side of tension rafter. (FIG. 6A)

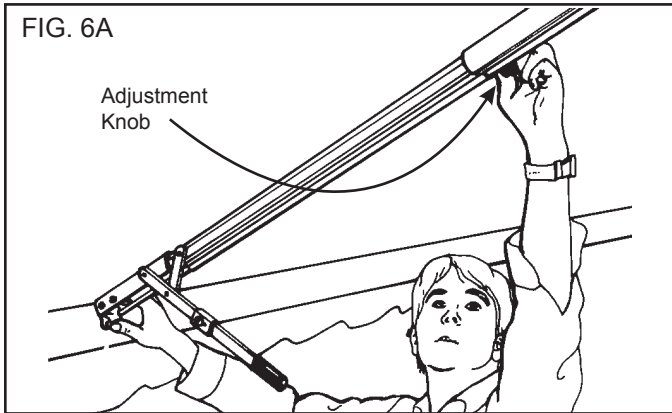

- B. Grasping the tension mechanism lever, carefully move it up even with the tension rafter and slide the lock over the lever to secure the rafter. (FIG. 6B) This step pushes the roller tube out and stretches the fabric taut. The tension rafter is designed to use the full stroke of the tension mechanism for 25 foot awnings. Shorter awnings may require less tension.

The amount of tension may be lessened by starting with the lever positioned at less of an angle prior to tightening the knob. (FIG. 6C)

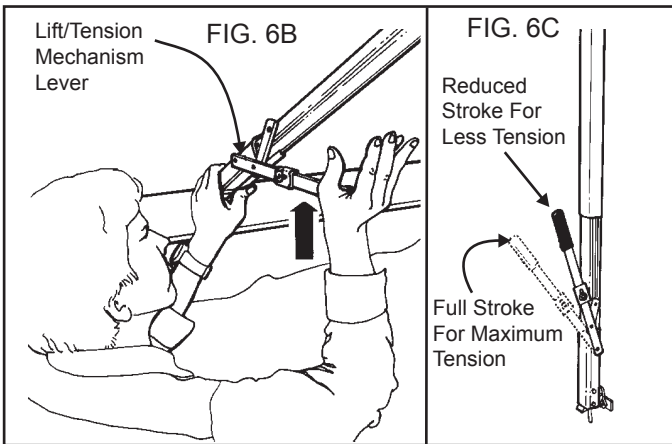

7. A. If center support is to be used, release it from the tension rafter at this time by loosening the larger 1-7/8" dia. adjustment knob. (FIG. 7A)

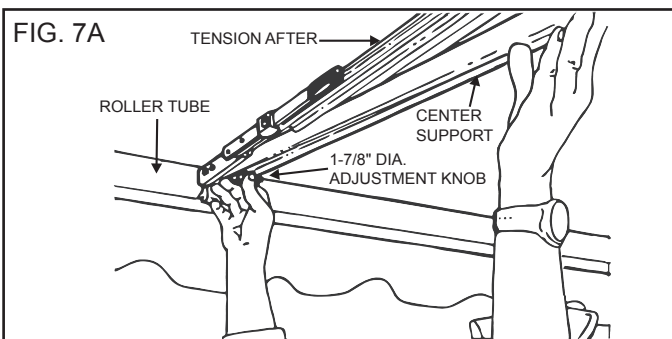

- B. Slide the knob toward the vehicle and carefully swing the center support down placing the foot of the center support on the ground. (FIGS. 7B, 7C & 7D)

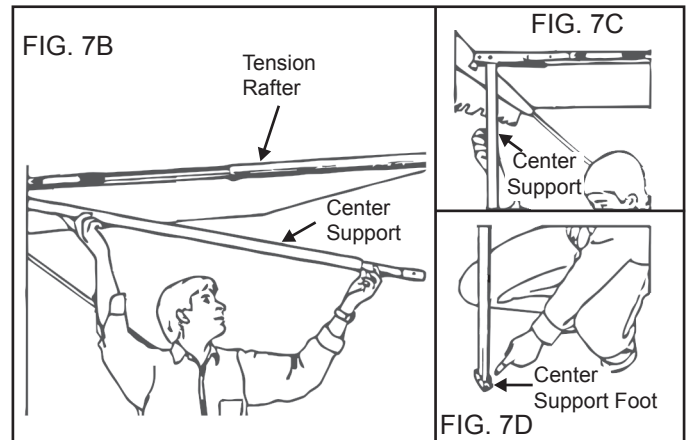

8. The awning can now be raised to a higher position with no further adjustment to the tension rafter required. If the awning is to be placed into patio position, release the roller tube lock lever before detaching and rotating the awning arms out. This will allow the rafter roller bracket to continue to fit snugly against the roller tube.
9. When the awning is set in desired position, raise the center support to hold the roller tube at desired height and secure by firmly tightening the adjustment knob. (FIG. 8)

⚠ WARNING

DO NOT extend center support so that less than 3" of the secondary arm remains in the main arm. (FIG. 8)

10. Anchor the foot of the center support by driving the two (2) metal spikes provided into the ground. (FIG. 9)

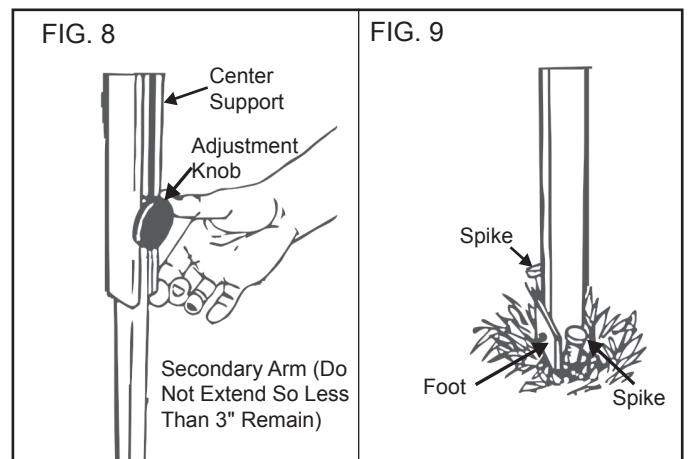

TO CLOSE:

⚠ WARNING

When used on curved vehicle that does not allow for permanent installation, the tension rafter **MUST** be removed from the side of vehicle before traveling.

11. Remove spikes from center support foot and loosen adjustment knob. (FIGS. 10 & 11)

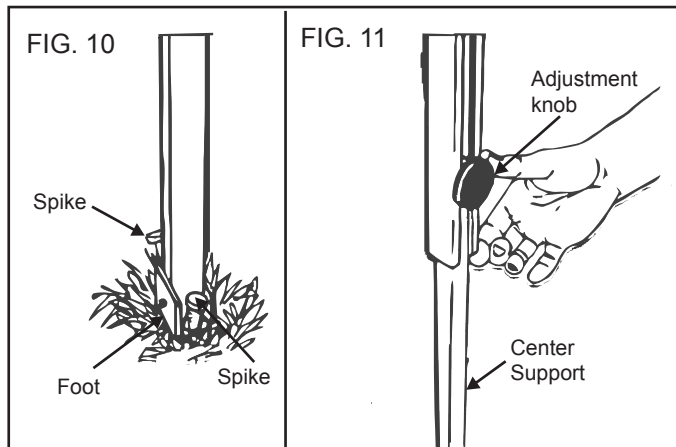

12. Lower the awning. If roller tube lock lever was released, be sure to return to ROLL DOWN POSITION so that the awning will not snap back against the coach when awning rafter arms are released.

13. Swing the center support up to the tension rafter and slide the dowel pin that the center support foot pivots on, into the opening of the channel tracks at the end of the inner rafter. (FIG. 12)

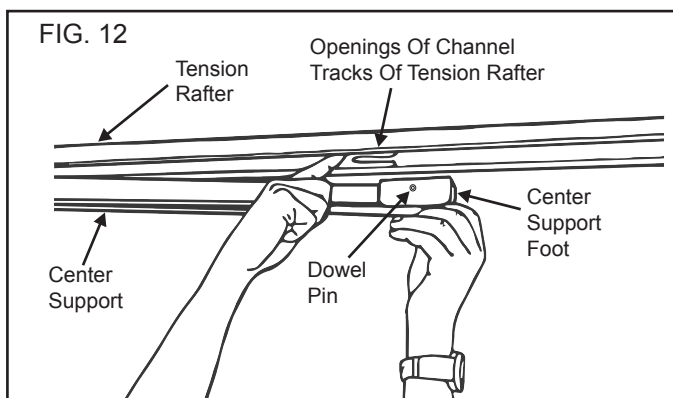

Make sure the pin is seated inside the channel tracks of the tension rafter before securely tightening the larger 1-7/8" adjustment knob.

⚠ WARNING

If the 3/16" dia. dowel pin of the center support foot is not seated inside the channel tracks of the tension rafter, the center support may fall during tension rafter operation and result in possible injury.

14. Relieve tension of the tension rafter by unlocking and carefully pulling the tension mechanism lever down. (FIG. 13)

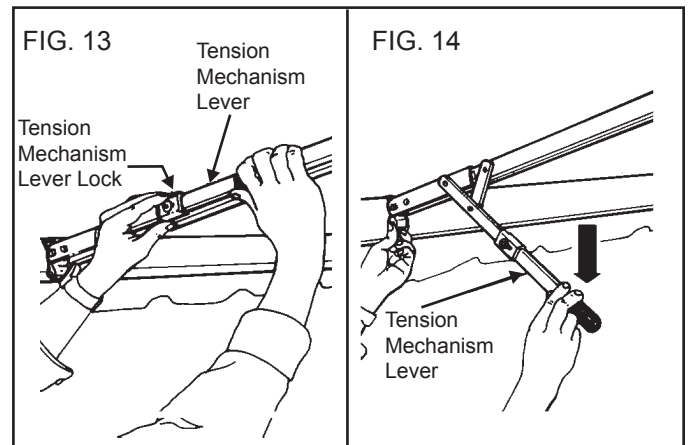

15. Loosen adjustment knob on side of tension rafter and push tension mechanism lock up, slide tension mechanism lever down. (FIGS. 14A, 14B & 14C)

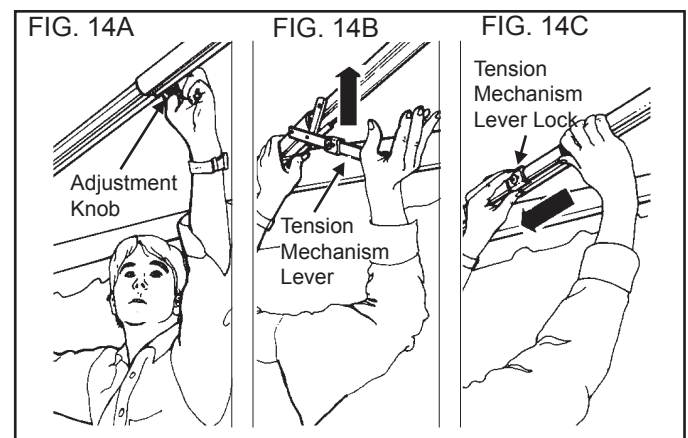

16. Remove tension rafter from roller tube and attach to bottom bracket on side of vehicle with ball lock pin. (FIG. 15)

17. A. Slide tension mechanism lock up to unlock lever and pull lever forward. (FIG. 16)
B. Close awning per awning Operation Instructions.

18. Tighten knob on side of tension rafter and push tension mechanism lever back. This will lift the awning. The amount of lift may be lessened by starting with the lever positioned at less of an angle before tightening the adjustment knob.

INSTALLATION OF CENTER SUPPORT

APPLICATION:

The Optima Center Support can be used on any automatic roll-up type awning that uses a roller tube. It may be purchased separately and used by itself as a center support or added to the Optima Tension Rafter/Cradle Support or purchased in the complete Optima Tension Rafter System combination.

IMPORTANT: Read and understand the entire installation procedure before starting installation.

NOTE: Dometic Corporation assumes no liability for damages or injuries resulting from installation or operation of this product.

Dometic Corporation reserves the right to modify appearances and specifications without notice.

Tools required:

- Measuring Tape
- Center Punch
- Pencil
- 7/16" Wrench or Socket
- Electric Drill
- Hammer
- 1/4" Drill Bit

1. Assemble the center support by installing the roller bracket assembly onto the main arm with a 1/4-20 x 1-3/4" hex head bolt and lock nut with nylon insert. (FIG. 1)

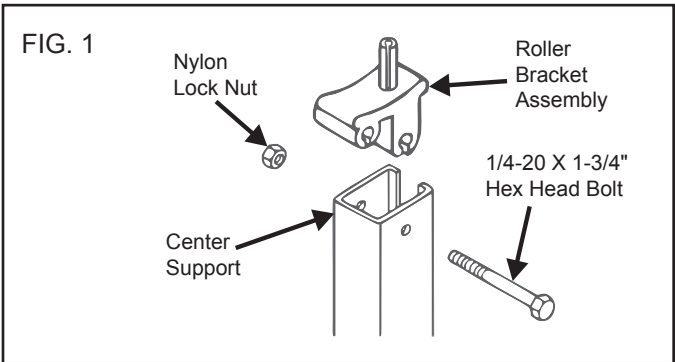

NOTE: If the Optima Center Support is being used in conjunction with the Optima Tension Rafter, the roller bracket is not required and the center support should be attached to the tension rafter as pictured in FIG. 2. To attach center support, use 1/4-20 nut and 1/4-20 x 2-1/2" hex head bolt in the tension rafter. Install the center support with the two rubber sleeves (provided) on both sides of the center support. (FIG. 2)

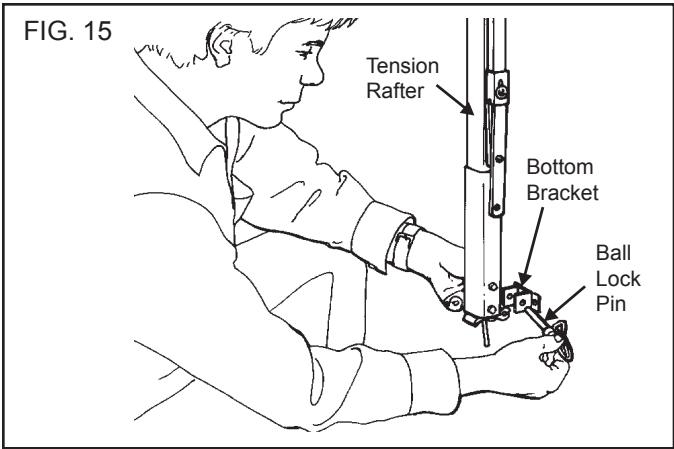

19. Slide lock on lever down to secure mechanism. Optima Tension Rafter System is now functioning as a cradle support and is ready for travel. (FIGS. 17 & 18)

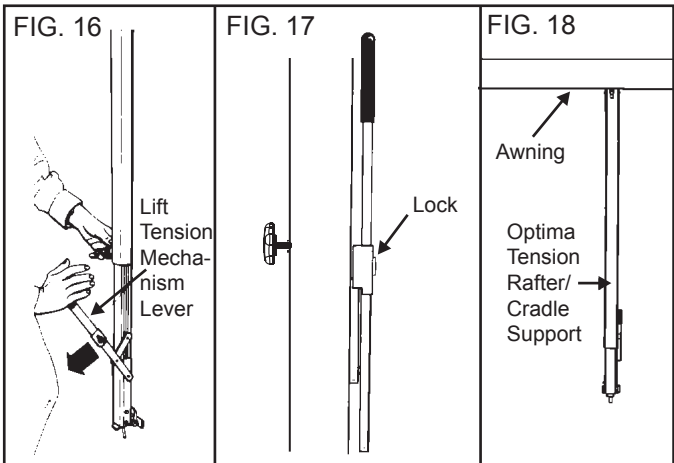

OPERATION OF CENTER SUPPORT

- Open the awning and set to desired height (FIG. 4)
- Insert the dowel pin in the roller bracket into the 1/4" dia. hole drilled in the roller tube. (FIG. 5)

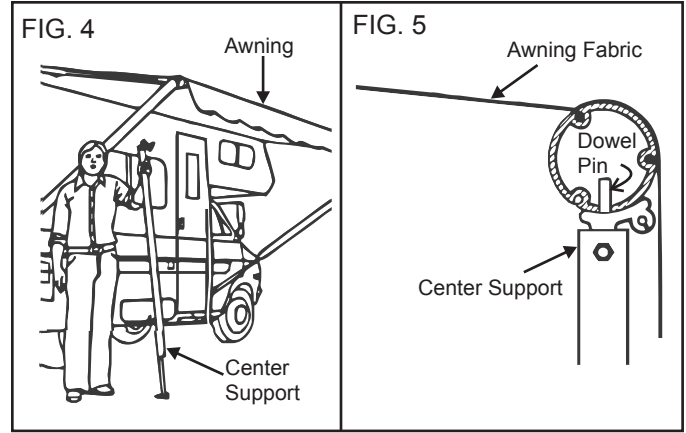

- Extend the center support up to hold the roller tube at desired height and tighten the adjustment knob firmly. (FIGS. 6 & 7)

⚠ CAUTION

DO NOT extend center support so less than 3" of the secondary arm remains in the main arm of the center support. (FIG. 7)

- Anchor the foot of the center support by driving the two metal spikes (provided) into the ground. (FIG. 8)

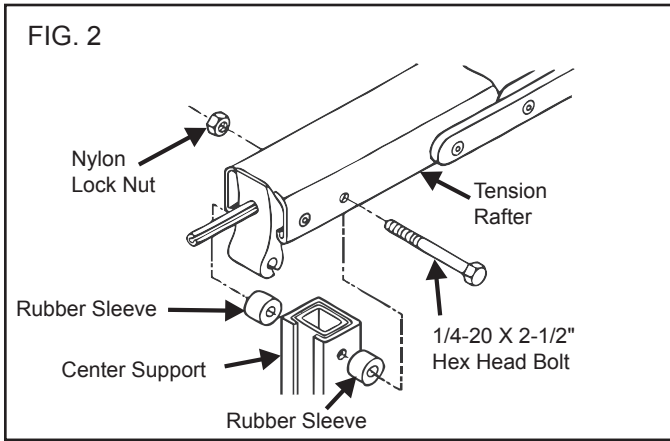
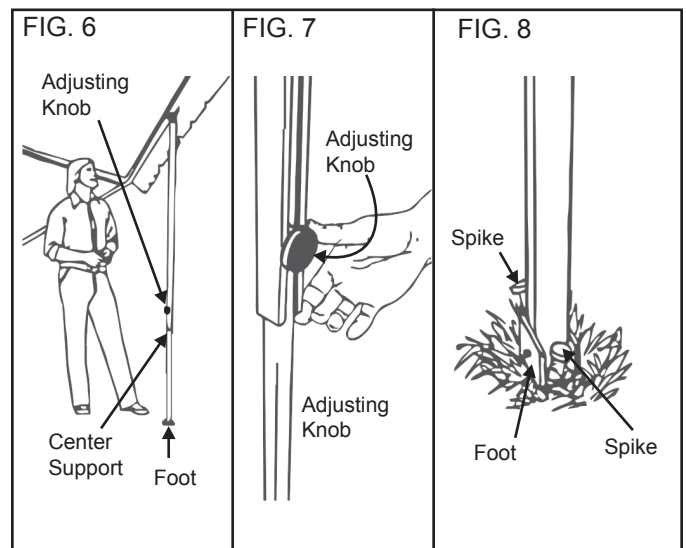

- Set up the awning so that the roller tube is at eye level.
- Locate the center of the awning or, if tension rafter is being used, locate its mounting position.
- Mark the spot on the bottom center of the roller tube where the dowel of the roller bracket is to be inserted. (FIG. 3)

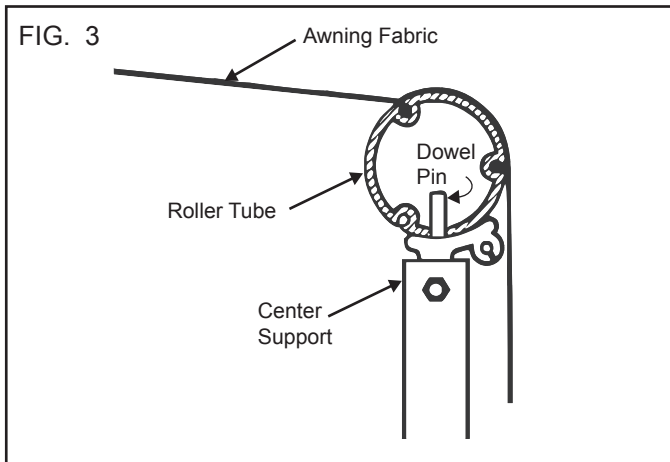

- It is recommended to first center-punch before drilling a 1/4" dia. hole in the roller tube.
- The center support is now ready for operation.